

BREU-K SERIES CAM CLUTCH

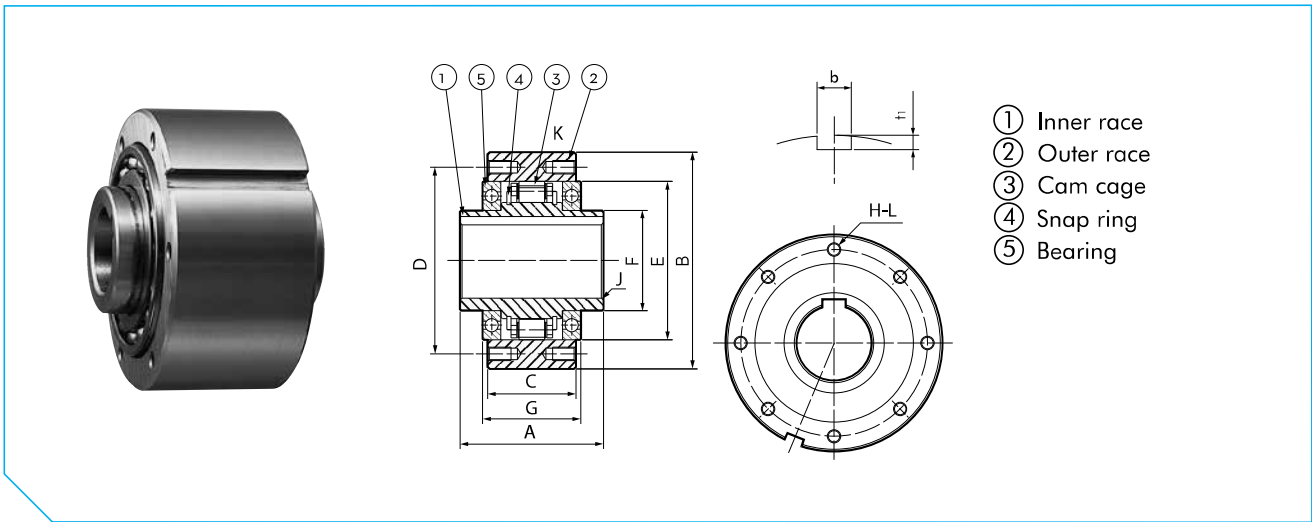

BREU-K

Dimensions in mm

Model	Torque Capacity Nm	Inner Race Overrunning Speed		Max. Engagement Speed r/min	Bore Size H7	Inner Race Keyway	A	B h7	C	D	E	F	G	H-L	K	J	Outer Race Keyway		Approx. Mass kg/pc
		Min. r/min	Max. r/min														b P10	t1	
BREU30-K	607	880	3600	350	30	8 x 3.3	76	100	51	87	75	45	56	6-M6	10	1.0	8 x 4.0	2.7	
BREU35-K	686	780	3600	300	35	10 x 3.3	79	110	50	96	80	50	56	6-M6	12	1.0	10 x 5.0	3.2	
BREU40-K	980	720	3600	300	40	12 x 3.3	86	125	53	108	90	55	59	6-M8	14	1.3	12 x 5.0	4.4	
BREU45-K	1078	670	3600	280	45	14 x 3.8	86	130	53	112	95	60	59	8-M8	14	1.3	14 x 5.5	4.7	
BREU50-K	1715	610	3600	240	50	14 x 3.8	94	150	64	132	110	70	72	8-M8	14	1.3	14 x 5.5	7.6	
BREU55-K	1960	580	3600	220	55	16 x 4.3	104	160	66	138	115	75	72	8-M10	16	1.5	16 x 6.0	8.9	
BREU60-K	3479	490	3600	200	60	18 x 4.4	120	170	84	150	125	80	95	10-M10	16	1.5	18 x 7.0	12.5	
BREU70-K*	4735	480	3600	200	70	20 x 4.9	134	190	95	165	140	90	108	10-M10	16	1.8	20 x 7.5	17.2	
BREU80-K*	6517	450	3600	190	80	22 x 5.4	144	210	100	185	160	105	108	10-M10	16	1.8	22 x 9.0	22.4	
BREU90-K*	8526	420	3000	180	90	25 x 5.4	158	230	115	206	180	120	125	10-M12	20	2.0	25 x 9.0	30.3	
BREU100-K*	14210	460	2500	180	100	28 x 6.4	186	270	124	240	210	140	135	10-M16	24	2.0	28 x 10.0	45.5	
BREU130-K*	20384	420	2200	180	130	32 x 7.4	212	310	152	278	240	160	168	12-M16	24	2.5	32 x 11.0	67.0	
BREU150-K*	33908	370	1300	180	150	36 x 8.4	246	400	180	360	310	200	194	12-M20	32	2.5	36 x 12.0	145.0	

*= Non-stock item

Installation and Usage

1. By installing both parts on the opposite side, the direction of rotation can be changed.
2. When mounting the clutch onto the shaft, apply pressure to the inner race but never to the outer race. Tap the inner race lightly with a soft hammer moving around the race circumference so the Cam Clutch moves slowly and uniformly onto the end of the shaft.
3. All models are pre-greased. The ambient temperature range is -40°C to +40°C. Too much additional grease to both bearing inhibits the basic Cam Clutch function.

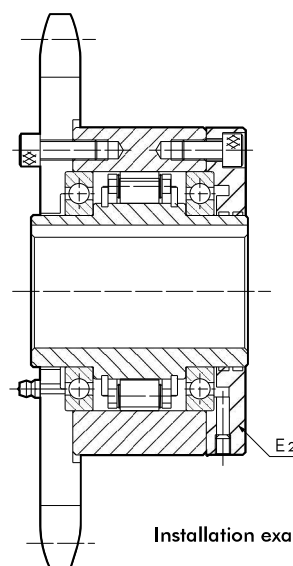

Installation example 1

Note:

Current stock items are basic BREU type clutches without keyway on outer race. Please note that Basic BREU type clutches will gradually be replaced by BREU-K type clutches.